



Magnetic Materials

Mould Shapes & Available Sizes

Sintered NdFeB (Neodymium Iron Boron) Magnets **Magnetic Characteristics**

Factory Material GRADE	Remanence				Coercivity				Intrinsic		Max. Energy Product (BH)max				Max Working Temp		
	Br				Hc b				Coercivity		Hc i						
	Kg		T		K Oe		KA/m		KOe	KA/m	MGOe		KJ/m ³		Deg C		
	typ.	min.	typ.	min.	typ.	min.	typ.	min.			typ.	min.	typ.	min.			
N27	10.6	10.2	1.06	1.02	10.5	9.6	836	765	12	955	27	25	215	199	* 80		
N30	11.2	10.8	1.12	1.08	10.5	9.8	836	780	12	955	30	28	239	223	* 80		
N33	11.6	11.3	1.16	1.13	11.0	10.3	876	820	12	955	33	31	263	247	* 80		
N35	12.1	11.7	1.21	1.17	11.2	10.8	892	860	12	955	35	33	279	263	* 80		
N37	12.4	12.0	1.24	1.2	11.5	10.8	915	860	12	955	37	35	295	279	* 80		
N40	12.9	12.5	1.29	1.25	11.5	10.6	915	844	12	955	40	38	318	303	* 80		
N43	13.3	13.0	1.33	1.3	10.5	10.0	836	796	11	876	43	41	342	326	* 80		
N45	13.7	13.3	1.37	1.33	10.5	10.0	836	796	11	876	45	43	350	342	* 80		
N50	14.2		1.42		8.5		677		10	800	49- 51	49	390-416	390	* 80		
N30M	11.2	10.8	1.12	1.08	10.5	9.8	836	780	14	1114	30	28	239	223	* 100		
N33M	11.7	11.3	1.17	1.13	11.0	10.3	876	820	14	1114	33	31	263	247	* 100		
N35M	12.1	11.7	1.21	1.17	11.2	10.8	892	860	14	1114	35	33	279	263	* 100		
N37M	12.4	12.0	1.24	1.20	11.5	10.8	915	860	14	1114	37	35	295	279	* 100		
N40M	12.9	12.5	1.29	1.25	11.5	10.6	915	844	14	1114	40	38	318	303	* 100		
N27H	10.6	10.2	1.06	1.02	10.5	9.6	836	765	17	1353	27	25	215	199	* 120		
N30H	11.2	10.8	1.12	1.08	10.5	9.8	836	780	17	1353	30	28	239	223	* 120		
N32H	11.5	11.2	1.15	1.12	11.0	10.3	876	820	17	1353	32	30	255	239	* 120		
N35H	12.1	11.7	1.21	1.17	11.2	10.8	892	860	17	1353	35	33	279	263	* 120		
N37H	12.4	12.0	1.24	1.20	11.5	10.8	915	860	17	1353	37	35	295	279	* 120		
N40H	12.9	12.5	1.29	1.25	11.5	10.6	915	844	17	1353	40	38	318	303	* 120		
N27SH	10.6	10.2	1.06	1.02	10.5	9.6	836	765	20	1595	27	25	215	199	* 150		
N30SH	11.2	10.8	1.12	1.08	10.5	9.8	836	780	20	1595	30	28	239	223	* 150		
N32SH	11.5	11.2	1.15	1.12	11.0	10.3	876	820	20	1595	32	30	255	239	* 150		
N35SH	12.1	11.7	1.21	1.17	11.2	10.8	892	860	20	1595	35	33	279	263	* 150		
N25UH	10.2	9.7	1.02	0.97	9.6	9.4	764	748	24	1910	25	23	199	183	* 160		
N28UH	10.8	10.4	1.08	1.04	10.2	9.8	812	780	24	1910	28	26	223	207	* 160		
N30UH	11.2	10.8	1.12	1.08	10.6	10.1	844	804	24	1910	30	28	239	223	* 160		

Dimension Range (All dimensions are in millimetres. Magnets can be machined to requirements)

	<p>DISC</p> <table border="1"> <thead> <tr> <th></th> <th>Diameter</th> <th>Thickness (A)</th> </tr> </thead> <tbody> <tr> <td>Max.</td> <td>100</td> <td>50</td> </tr> <tr> <td>Min.</td> <td>1.2</td> <td>0.5</td> </tr> </tbody> </table>		Diameter	Thickness (A)	Max.	100	50	Min.	1.2	0.5			
	Diameter	Thickness (A)											
Max.	100	50											
Min.	1.2	0.5											
	<p>BLOCK</p> <table border="1"> <thead> <tr> <th></th> <th>Length</th> <th>Width</th> <th>Thickness (A)</th> </tr> </thead> <tbody> <tr> <td>Max.</td> <td>150</td> <td>100</td> <td>25</td> </tr> <tr> <td>Min.</td> <td>1.5</td> <td>1.5</td> <td>0.5</td> </tr> </tbody> </table>		Length	Width	Thickness (A)	Max.	150	100	25	Min.	1.5	1.5	0.5
	Length	Width	Thickness (A)										
Max.	150	100	25										
Min.	1.5	1.5	0.5										

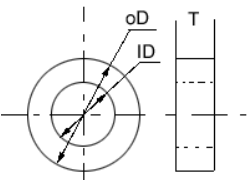
	RING		
	Outer Diameter	Inner Diameter	Thickness (A)
	Max. 100	95	50
	Min. 3.8	1.2	0.5

IMPORTANT NOTES on sintered NdFeB magnets:

- * **MAX. Working Temperature** is only for reference, depending on the magnetic circuit application. Temperature is changeable due to the ratio of length and diameter, as well as environmental factors. When L/D ratio of testing piece is equal to 0.7, the open flux irreversible loss at Max. Working Temperature less/equal 5% is guaranteed. (L=means magnetization direction length. D= means diameter of magnetic pole surface.)
- Users are advised to consult us on any application involving temperatures close to 150 Centigrade.

Bonded NdFeB (Neodymium Iron Boron) Magnets Material Characteristics

Factory Material code		NEOBM-4	NEOBM-6	NEOBM-8	NEOBM-10	NEOBM-12
Br Residual Induction	MT KGs	350-450 3.5-4.5	500-600 5-6	550-600 5.5-6	650-700 6.5-70	700-800 7-8
Hc B Coercive Force	KA/m K Oe	240-280 3.0-3.5	320-360 4-4.5	360-400 4.5-5	400-440 5-5.5	440-480 5.5-6
Hc i Intrinsic Coercive Force	KA/m K Oe	640-800 8-10	640-800 8-10	960-1120 12-14	640-800 8-10	720-880 9-11
(BH) max Maximum Energy Product	KJ/m³ MG.Oe	24-32 3-4	40-56 5-7	60-68 7.5-8.5	72-80 9-10	80-96 10-12

Physical Properties

Average Reversible Temperature Coefficient ----- ---	0.09-0.1% / degree C
Coefficient of Thermal Expansion (25-200) ----- -----	4.8X10 ⁻⁶ / degree C
Compressive Strength ----- ----	96kg/cm
Curie Temperature T c ----- --	400 degrees centigrade
Density ----- -	5.5-5.8g/cm ³ (Neobm6) 5.8-6.0g/cm ³ (Neobm8) 5.8-6.2g/cm ³ (Neobm10) 6.2-6.6g/cm ³ (Neobm12)
Electrical Resistivity ----- --	14000 , -cm
Hardness ----- -----	35-38HRB (Neobm8/10/12) 40-45HRB (Neobm4/6)
Max. Working Temperature ----- --	110 centigrade

Required Magnetizing Force (Open Circuit) ----- ---	25KOe
--	-------

Notes:

Magnetic and physical properties are at room temperature.

Max. Working temperature is dependent upon permeance coefficient coating and environment.

Magnets can be machined to per customers' requirements.

Remark: 1mT=10Gs; 1KA/m=4πYOe; 1KJ/m³ = 4πx10⁻²MGOe;

FERRITE MAGNETS

Magnetic Characteristics (In SJ/T 10410-93 Standard)

Factory Material Code	Remanence		Coercivity		Intrinsic		Max.Energy Product (BH) _{max}	
	Br		Hcb		Coercivity			
	MT	KG	KA/m	KOe	KA/m	KOe	KJ/m ³	MGOe
Y8T	200~235	2.0~2.35	125~160	1.57~2.01	210~280	2.64~3.52	6.5~9.5	0.8~1.2
Y20	320~380	3.2~3.8	135~190	1.70~2.38	140~195	1.76~2.45	18.0~22.0	2.3~2.8
Y22H	310~360	3.1~3.6	220~250	2.77~3.14	280~320	3.52~4.02	20.0~24.0	2.5~3.0
Y23	320~370	3.2~3.7	170~190	2.14~2.38	190~230	2.39~2.89	20.0~25.5	2.5~3.2
Y25	360~400	3.6~4.0	135~170	1.70~2.14	140~200	1.76~2.51	22.5~28.0	2.8~3.5
Y26H	360~390	3.6~3.9	220~250	2.77~3.14	225~255	2.83~3.21	23.0~28.0	2.9~3.5
Y27H	370~400	3.7~4.0	205~250	2.58~3.14	210~255	2.64~3.21	25.0~29.0	3.1~3.7
Y28	370~400	3.7~4.0	175~210	2.20~2.64	180~220	2.26~2.77	26.0~30.0	3.3~3.8
Y30H-1	380~400	3.8~4.0	230~275	2.89~3.46	235~290	2.95~3.65	27.0~32.0	3.4~4.1
Y30H-2	395~415	3.95~4.15	275~300	3.46~3.77	310~335	3.90~4.21	28.5~32.5	3.5~4.0
Y32	400~420	4.0~4.2	160~190	2.01~2.38	165~195	2.07~2.45	30.0~33.5	3.8~4.2
Y33	410~430	4.1~4.3	220~250	2.77~3.14	225~255	2.83~3.21	31.5~35.0	4.0~4.4

LN9	680	6800	30	380	9.0	1.13	6.9	Alnico 3	-0.03	-0.02	810	450
LN10	600	6000	40	500	10.0	1.20	6.9		-0.03	-0.02	810	450
LNG12	720	7200	45	500	12.4	1.55	7.0	Alnico 2	-0.03	-0.02	810	450
LNG13	700	7000	48	600	12.8	1.60	7.0		-0.03	-0.02	810	450
LNG37	1200	12000	48	600	37.0	4.65	7.3	Alnico 5	-0.02	0.02	860	525
LNG40	1250	12500	48	600	40.0	5.00	7.3					
LNG44	1250	12500	52	650	44.0	5.50	7.3					
LNG52	1300	13000	56	700	52.0	6.50	7.3					
LNG60	1350	13500	59	740	60.0	7.50	7.3	Alnico 5-7				
LNGT28	1000	10000	58	720	28.0	3.50	7.3	Alnico 6	-0.02	0.03	860	525
LNGT36J	700	7000	140	1750	36.0	4.50	7.3	Alnico 8 HC	-0.025	0.02	860	550
LNGT18	580	5800	100	1250	18.0	2.20	7.3	Alnico 8	-0.025	0.02	860	550
LNGT32	800	8000	100	1250	32.0	4.00	7.3	Alnico 8	-0.025	0.02	860	550
LNGT40	800	8000	110	1380	40.0	5.00	7.3					
LNGT60	900	9000	110	1380	60.0	7.50	7.3	Alnico 9	-0.025	0.02	860	550
LNGT72	1050	10500	112	1400	72.0	9.00	7.3					

Notes:

If special methods are applied, customized properties can be achieved. *=Isotropic Others=Anisotropic

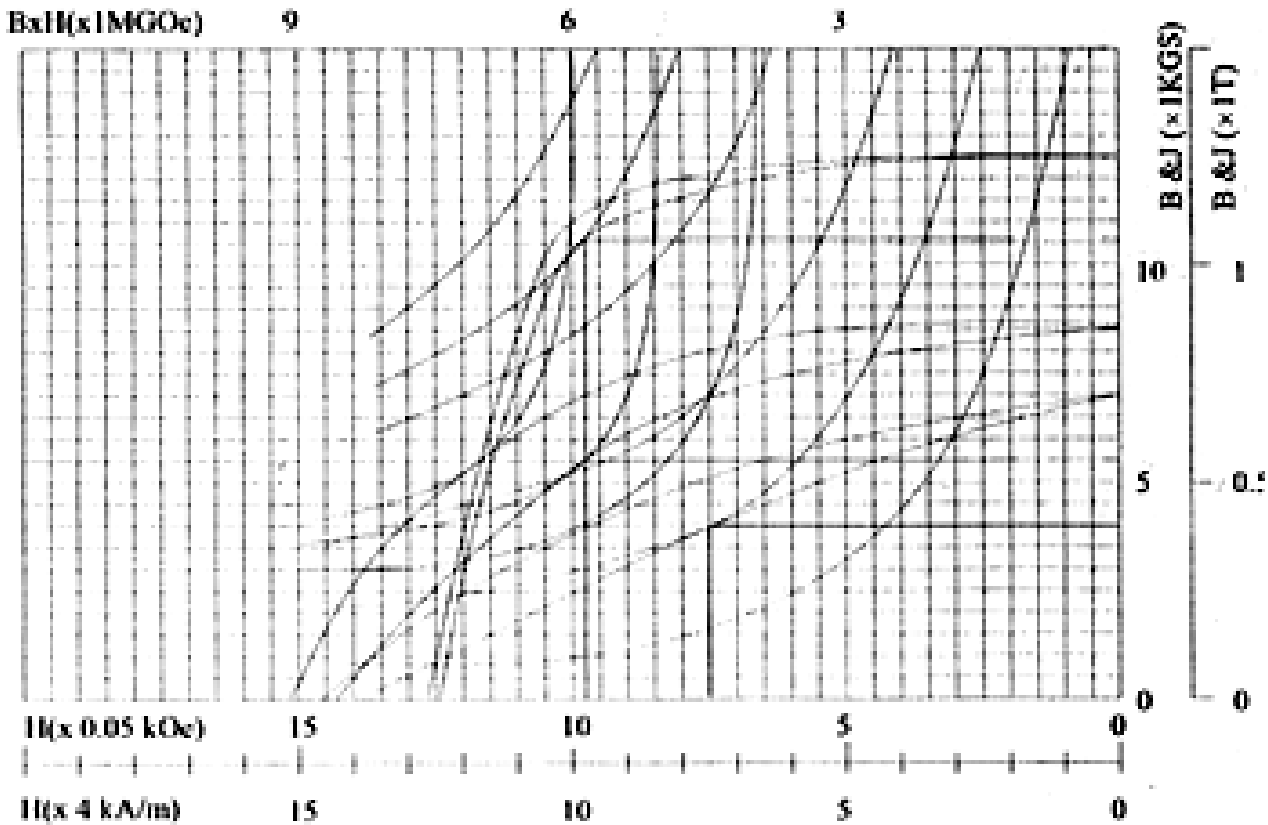

If special methods are applied, customized properties can be achieved.

Range of available mould sizes :

Ferrite Magnets ONLY --- It should be noted that not all the ring magnet sizes can be radially magnetised

[Top of the Document](#)

Block Shape Size L x W x H (mm)		Disc Shape Size D x H (mm)	
12 x 7 x 3~7	45 x 25 x 3~20	5 x 2~8	25 x 2~10
12 x 12 x 2~7	47.6 x 9.5 x 3~15	6 x 2~8	25.4 x 2~10
12.8 x 9.8 x 2~7	47.6 x 22.2 x 3~17	6.35 x 2~8	25 x 3~17
13.3 x 7.8 x 2~6	49 x 19 x 3~20	7.5 x 2~14	27 x 3~3.2
14.8 x 9.5 x 2~6	50 x 19 x 3~20	8 x 2~10	28 x 3~16
16.9 x 9.6 x 2~6	50 x 25 x 3~20	9.4 x 2~9	29.8 x 2~12
18 x 13 x 2~7	50 x 50 x 3~24	10 x 2~15	30 x 3~20
18 x 15 x 4.75 x 2~7	50.8 x 25.4 x 3~26	10.5 x 2~10	32 x 3~17
19 x 13 x 2~8	57.5 x 32.5 x 3~18	12 x 2~6	34.5 x 3~18
19 x 17.5 x 2~7	59 x 24 x 3~20	12.5 x 2~6	36 x 3~12
19.7 x 10 x 2~7	59.3 x 29.5 x 3~25	13 x 2~6	38 x 3~20
21 x 19 x 2~7	60 x 20 x 3~24	13.5 x 2~6	39 x 3~10
23.5 x 13.5 x 5 x 2~8	60 x 25 x 3~20	14 x 2~6	40 x 3~16
24 x 13.4 x 4.5 x 2~6	60 x 30 x 3~25	15 x 2~8	43.5 x 3~16
24 x 24 x 5.5 x 2~18	75 x 50 x 3~23	15.7 x 2~8	45 x 3~16
24 x 24 x 8 x 2~8	76 x 41 x 3~26	16 x 2~6	50 x 3~20
25 x 8 x 2~6	82 x 30.6 x 6.3 x 3~20	16.38 x 2~11	51 x 3~18
25 x 10 x 2~6	85 x 65 x 3~28	17.5 x 2~6	53 x 3~12
25 x 10 x 3.2 x 2~6	87 x 66 x 3~22	18 x 2~10	55 x 3~20
25 x 19 x 2~7	90 x 34 x 3~24	19 x 2~10	70 x 3~17
25 x 20 x 2~10	100 x 100 x 3~27	20 x 2~10	72 x 3~16
30 x 10 x 3~7	105 x 105 x 5~25	21.6 x 2~10	75 x 3~23
30 x 20 x 3~24	127 x 50 x 3~26	22 x 2~28	80 x 3~29
30 x 30 x 3~24	131 x 51 x 3~24	23 x 2~10	86 x 3~23
35 x 15 x 3~6	150 x 100 x 3~30		
40 x 12 x 2~7	160 x 80 x 3~30		
40 x 20 x 3~20	152.4 x 101.6 x 3~29		
40 x 25 x 3~24	270 x 90 x 5~32		
40 x 40 x 3~17	INCH SIZES		
42 x 25 x 3~15	4" x 3" x 3~30		
44 x 22 x 3~10	6" x 2" x 3~30		

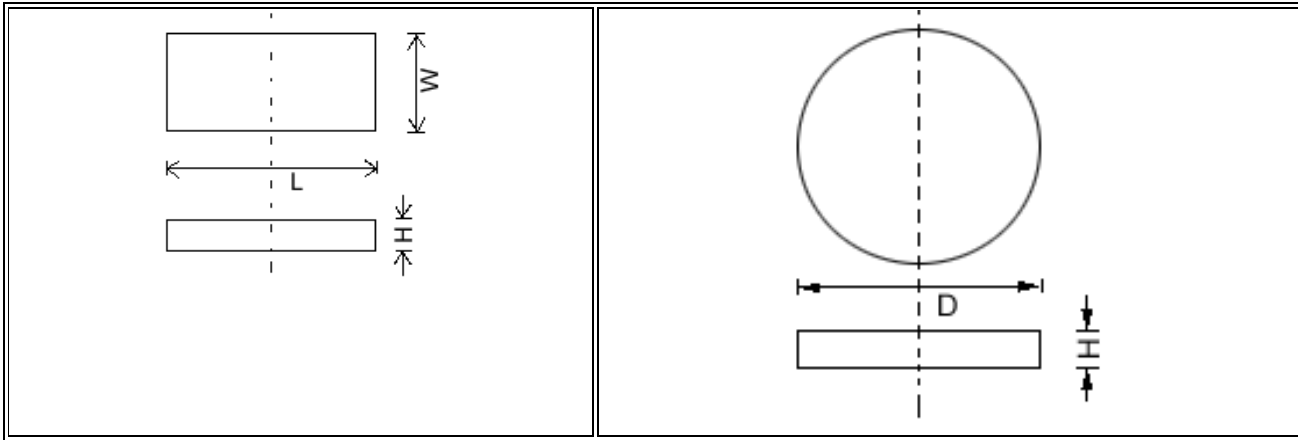

Dimension tolerance: L= +/- 2%; W= +/- 2%; H= +/- 0.1mm (**block**). D= +/- 2%; H= +/- 0.1mm (**disc**).
 Dimensions other than stated will be supplied on request, and may include mould-manufacturing costs.

FERRITE MAGNETS

Y10T DRY PRESSED SHAPE SIZES

DISC SHAPE D x H (mm)	RING SHAPE D x d x H (mm)	BLOCK SHAPE L x W x H (mm)
4 x 8.7	3.6 x 0.98 x 4.2	9 x 9 x 50(N.S)
6 x 3.4	10x2.2x5	13x5x5
8 x 4~5	10 x 4.2 x 14.5	13 x 8 x 4.5
9.4 x 11.3~14.7	10.16 x 2.36 x 5	16.9 x 9.6 x 4.9
10 x 4~8	10.67 x 2.92 x 6.1	18 x 15 x 4.8 x μ 4.6
11.1 x 4.75	12 x (F3.2 x 3.2) x 12	20 x 10 x 4-5
11.5 x 4	12.4 x 5.8 x 11.2	20 x 14 x 3.8 x 4.0
12 x 4~12	12.7 x 2.36 x 6.35	22 x 16 x 7
12.5 x 4~6	14 x 4 x 3	23.5 x 7.7 x 4.8
12.7 x 6.35	15 x 10 x 5	24 x 14 x 4.5 x 5
14.5 x 6.6	14.9 x 7.6 x 14	25.4 x 19.05 x 4.75 x 7.11
14.9 x 5.2	15 x 00 x 5~7	26 x 4x5
16.4 x 4	17.35 x 4 x 5	28 x 15 x 5
17.5 x 4	9.5 x 6 x 3.5	29.5 x 29.5 x 5
17.5 x 5	19.56 x 13.6 x 9.26	30 x 10 x 3
19 x 7.8	20 x 5.3~11.3 x 4	32 x 8 x 5
19.65 x 5	20 x 4 x 4	47 x 21 x 10
20 x 3~5	20 x 9 x 5	50 x 14 x 10
22 x 4	20 x 13.6 x 9.25	50 x 15 x 6
24.7 x 3.75	21.85 x 15.5 x 5.5~15	50 x 50 x 3
25 x 3	22 x 6 x 10	54 x 13 x 10(N.S)
25.4 x 4.76~6	22 x 16 x 5	70 x 16 x 10(N.S)
28.6 x 4.75	23.75 x 4.15 x 5	
35 x 3	24.7 x 4.15 x 5	
	24.3 x 7.1 x 9.5 x 7 x 2.5	
	30 x 20 x 5	
	37 x 17 x 14	

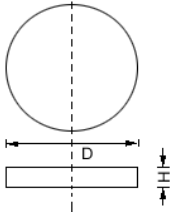
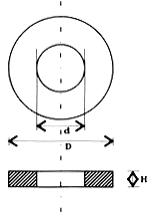
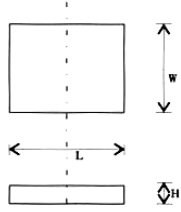
	38 x 28 x 5	
	54.05 x 38.5 x 25	
	79.68 x 45.9 x 12.7	
		

FERRITE MAGNETS

RING SHAPED SIZES

D x d x H (mm)		
8 x 3 x 2~9	20 x 4.3 x 2~10	30 x 9.65 x 3~20
9.4 x 4 x 2~9	(ID with double-faced groove)	30 x 10.4 x 3~20
10 x 3 x 2~6	20 x 12 x 4	30 x 12 x 3~20
10 x 4 x 2~6	20.5 x 9.5 x 2~9	30 x 12.5 x 3~20
10 x 4.5 x 2~10	20.5 x 10 x 2~9	30 x 15 x 3~20
10 x 5 x 2~6	21.2 x 12 x 2~10	30 x 16 x 3~20
10 x 5.5 x 2~6	21.6 x 5.5 x 2~10	30 x 18 x 3~20
10 x 6 x 2~6	21.6 x 13 x 2~10	30 x 20 x 3~20
11.5 x 5 x 2~6	22 x 7.32 x 2~10	30 x 24 x 3~20
11.75 x 7 x 2~6	22 x 8 x 2~10	32 x 8 x 3~17
(OD with groove)	22 x 10 x 2~10	32 x 8.5 x 3~17
12.1 x 3 x 2~6	22 x 11.5 x 2~10	32 x 9.5 x 3~17
12.5 x 3.5 x 2~6	22 x 12 x 2~10	32 x 12.5 x 3~17
13 x 8 x 2~6	22.8 x 13 x 2~10	32 x 15.3 x 3~17
13.1 x 2.6 x 2~6	23 x 4.3 x 2~10	32 x 16 x 3~17
13.5 x 5.5 x 2~6	23 x 6 x 2~10	32 x 18 x 3~17
13.5 x 8.5 x 2~6	23 x 7.32 x 2~10	32 x 19 x 3~17
13.5 x 5 x 2~6	23 x 10 x 2~10	32 x 20 x 3~17
13.35 x 6.4 x 1.96	23.7 x 14 x 2~10	32 x 20.75 x 3~17
13.8 x 5 x 2~6	24 x 14.1 x 2~10	32 x 22 x 3~17
13.8 x 5.5 x 2~6	24 x (15 x F8) x 3~10	34.5 x 12 x 3~18
13.8 x 7.5 x 2~6	24.3 x (15 x F8) x 3~10	34.5 x 10 x 3~18
14 x 3.3 x 2~8	24.6 x 8 x 2 x 3~10	35.8 x 22 x 3~20
14 x 3 x 2~6	24.6 x 15 x 2 x 3~10	35.8 x 18 x 3~20
14 x 4 x 2~6	25 x 19 x 3~5	35.8 x 25 x 3~20
14 x 5 x 2~6	25.4 x 5 x 2~10	36 x 12.5 x 3~12
14 x 5.5 x 2~6	25.4 x 5.5 x 2~10	36 x 15 x 3~12

15 x 6 x 2~8	25.4 x 6 x 2~10	36 x 15.36 x 3~12
15 x 6.5 x 2~8	25.4 x 7.5 x 2~10	36 x 16 x 3~12
15 x 10 x 2~8	25.4 x 11 x 2~10	36 x 18 x 3~12
15.06 x 9.525 x 2~8	25.4 x 12.5 x 2~10	36 x 19 x 3~12
16 x 4.5 x 2~6	25.4 x 13 x 2~10	38 x 14 x 3~20
16 x 5.5 x 2~6	26.2 x 12.3 x 2~10	38 x 18 x 3~20
16 x 7 x 2~6	26.9 x 5.5 x 2~10	39 x 22.5 x 3~10
16 x 7.5 x 2~6	27 x 12.5 x 2~10	40 x 12.5 x 3~16
16 x 11 x 2~6	27 x 5 x 2~10	40 x 15 x 3~16
16.3 x 6 x 2~6	27 x 17 x 2~10	40 x 18 x 3~16
17.5 x 7.5 x 2~6	28 x 5 x 2~10	40 x 19 x 3~16
17.5 x 9 x 2~6	28 x 5.5 x 2~10	40 x 22 x 3~16
17.5 x 11 x 2~8	28 x 6.5 x 2~10	40 x 22.5 x 3~16
18 x 3.5 x 2~10	28 x 10 x 3~16	40 x 25 x 3~16
18 x 4.2 x 2~10	28 x 14 x 2~10	40 x 26 x 3~16
18 x 4.3 x 2~10	28.5 x 5.5 x 2~9	40 x 28 x 3~16
18 x 6 x 2~10	28.5 x 10 x 2~10	43.5 x 31 x 3~16
18 x 6.5 x 2~10	28.8 x 13.3 x 2~6	45 x 18 x 3~16
18 x 7 x 2~10	29.8 x 8.5 x 2~12	45 x 19 x 3~16
18 x 8.5 x 2~10	29 x 10 x 2~10	45 x 20.3 x 3
18 x 11.5 x 2~10	29 x 5.3 x 2~10	45 x 22 x 3~16
19 x 6.5 x 2~10	30 x 8 x 2~10	45 x 23 x 3~16
19 x 11.5 x 2~10	30 x 8.5 x 2~10	45 x 24 x 3~16
20 x 10 x 2~10	30 x 9 x 2~10	45 x 29 x 3~16

(CONTINUED)

FERRITE MAGNETS RING SHAPED SIZES

D x d x H (mm)		
45 x 30 x 3~16	80 x 32 x 3~29	134 x 56 x 5~27
48 x 22 x 3~18	80 x 36 x 3~29	134 x 57 x 5~27
48 x 24 x 3~18	80 x 40 x 3~29	134 x 73 x 5~27
48 x 28 x 3~18	80 x 43 x 3~29	134 x 75 x 5~27
50 x 9 x 3~20	80 x 58 x 3~29	140 x 57 x 5~27
50 x 10 x 3~20	84 x 32 x 3~23	140 x 60 x 5~27
50 x 16 x 3~20	84 x 42 x 3~23	140 x 70 x 5~27

50 x 22 x 3~20	86 x 32 x 3~23	140 x 75 x 5~27
50 x 24 x 3~20	86 x 32.5 x 3~23	140 x 80 x 5~27
50 x 26 x 3~20	86 x 35 x 3~23	140 x 85 x 5~27
50 x 35 x 3~20	86 x 36 x 3~23	145 x 56 x 5~27
51 x 22 x 3~18	86 x 40 x 3~23	145 x 57 x 5~27
51 x 24 x 3~18	86 x 42 x 3~23	145 x 60 x 5~27
51 x 26 x 3~18	86 x 45 x 3~23	145 x 65 x 5~27
51 x 34.6 x 3~18	86 x 56 x 3~23	145 x 70 x 5~27
51 x 36 x 3~18	90 x 32 x 3~23	145 x 75 x 5~27
51 x 37 x 3~18	90 x 36 x 3~23	145 x 80 x 5~27
53 x 20.3 x 3~12	90 x 40 x 3~23	145 x 86 x 5~27
53 x 24 x 3~12	90 x 42 x 3~23	156 x 40 x 5~27
53 x 25.4 x 3~12	90 x 43 x 3~23	156 x 55 x 5~27
53 x 30 x 3~12	90 x 45 x 3~23	156 x 56 x 5~27
55 x 20 x 3~20	90 x 50 x 3~23	156 x 60 x 5~27
55 x 15 x 3~20	96 x 40 x 3~28	156 x 65 x 5~27
55 x 22.5 x 3~20	96 x 56 x 3~28	156 x 75 x 5~27
55 x 24 x 3~20	100 x 32 x 5~27	156 x 70 x 5~27
55 x 25 x 3~20	100 x 36 x 5~27	156 x 73 x 5~27
55 x 26 x 3~20	100 x 40 x 5~27	156 x 80 x 5~27
55 x 30 x 3~20	100 x 45 x 5~27	156 x 83.5 x 5~27
60 x 24 x 3~20	100 x 50 x 5~27	156 x 86 x 5~27
60 x 25 x 3~20	100 x 57 x 5~27	156 x 89 x 5~27
60 x 26 x 3~20	100 x 60 x 5~27	156 x 100 x 5~27
60 x 29 x 3~20	100 x 70 x 5~27	160 x 57/70 x 5~25
60 x 30.5 x 3~20	100 x 78 x 5~27	165 x 56 x 5~28
60 x 32 x 3~20	102 x 42 x 5~23	165 x 60 x 5~28
60 x 33 x 3~20	102 x 43 x 5~23	169 x 72.5 x 5~29
60 x 40 x 3~20	102 x 4 5x 5~23	169 x 86 x 5~29

60 x 43 x 3~20	102 x 51 x 5~23	181 x 56 x 5~29
61 x 24 x 3~15	102 x 57 x 5~23	181 x 57 x 5~29
61 x 32 x 3~15	102 x 60 x 5~23	181 x 73 x 5~29
63 x 42 x 3~20	102 x 75 x 5~23	181 x 83.5 x 5~29
65 x 24 x 3~21	109 x 45 x 5~28	181 x 86/90 x 5~29
65 x 25 x 3~21	109 x 60 x 5~28	181 x 95 x 5~29
65 x 32 x 3~21	110 x 38 x 5~21	193 x 80 x 5~27
68 x 32 x 3~15	110 x 43 x 5~21	193 x 83.5 x 5~27 (With a 12.7x2 hole)
68 x 40 x 3~15	110 x 45 x 5~21	
68 x 42 x 3~15	110 x 50 x 5~21	193 x 86/89 x 5~27
70 x 16 x 3~17	110 x 51 x 5~21	193 x 110 x 5~27
70 x 20 x 3~17	110 x 57 x 5~21	193 x 122 x 5~27
70 x 30.5 x 3~17	110 x 60 x 5~21	200 x 83 x 5~27
70 x 32 x 3~17	115 x 43 x 5~23	200 x 86 x 5~27
70 x 56 x 3~17	115 x 45 x 5~23	200 x 95 x 5~27
70 x 40 x 3~17	115 x 57 x 5~23	200 x 100 x 5~27
71 x 40 x 3~17	115 x 58.7 x 5~23(oval)	200 x 110 x 5~27
71 x 30.5 x 3~17	115 x 60 x 5~23	200 x 120 x 5~27
71 x 32 x 3~17	115 x 67 x 5~23	206 x 88.9 x 5~30
72 x 30.5 x 3~16	115 x 80 x 5~23	206 x 89 x 5~30
72 x 32 x 3~16	121 x 45 x 5~24	206 x 118 x 5~30
72 x 38 x 3~16	121 x 57 x 5~24	210 x 86 x 5~30
72 x 40 x 3~16	121 x 60 x 5~24	210 x 118 x 5~30
75 x 32 x 3~23	121 x 65 x 5~24	210 x 110 x 5~30
75 x 40 x 3~23	127 x 57 x 5~29	220 x 86 x 5~30
75 x 50 x 3~23	127 x 60 x 5~29	220 x 110 x 5~30
75 x 56 x 3~23	134 x 60 x 5~27	220 x 122 x 5~30
		225 x 120 x 5~30

Dimension tolerances: $D=2\%$; $d=\pm 2\%$; $H=\pm 0.1\text{mm}$.
Dimensions other than stated will be supplied upon request.

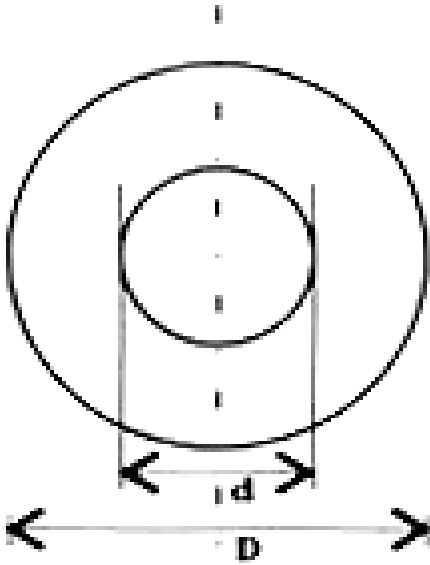

$\diamond H$

[Top of the Document](#)